

DT-DBC4R

Riser Distributor

User Manual

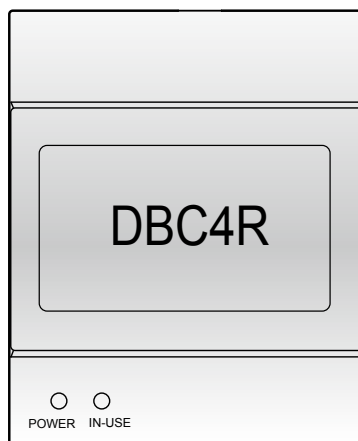

Please read this manual carefully before using the product you purchase, and keep it well for future use. We reserve the right to modify the specification in this manual at any time without notice.

1. Description

The DBC4R is a 4 output video amplifier.

- There are 2 working modes: riser mode and distributor mode;
- Separate isolation protection without affecting another devices on bus system;
- Short-circuit indication for convenient maintenance;
- Periodic self-detection mechanism for recovery.

2. Parts and Functions

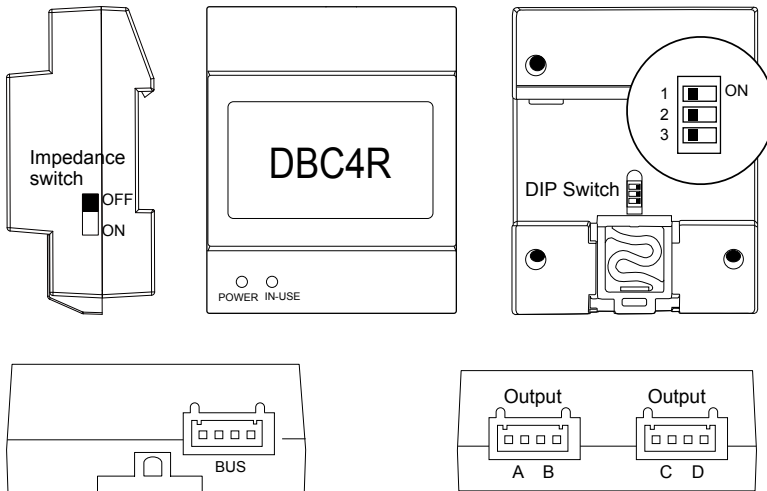

IN-USE Status indicator	POWER Video match indicator
Standby: off	not match: red
Device working: on	match: orange
Power protection: slow flash	
Device search mode: fast flash	

Impedance Switch: Video match switch.

Bus: Input port, bus connection port.

A,B,C,D: Output port, connect to indoor monitors.

DIP Switch: 3 bit DIP switches, about the DIP settings, see follows:

	ON	OFF
DIP1	the unit work in riser mode	the unit work in distributor mode
DIP2	the unit start to search the local monitors (for monitors with built-in power)	the unit stop to search the monitors (in normal use)
DIP3	Gain High	Gain Auto

Note:

- Operation mode: Protection mode will be activated once its connected devices are short circuited, and power supply for ABCD outputs will be turn off, the flashing in-use indicator shows the distributor is in the protection mode.
- Self-detection: System will auto check whether the short circuit is fixed or not, then recover the power supply, and in-user indication will be turn off;
- Detection period: Self-detection will be happened regularly according rules, and in-use indicator will flash rapidly three times when check happens;
1st detection will be happened in 10 seconds after short circuit;
2nd detection will be happened in 60 seconds after 1st detection;
3rd detection will be happened in 5 minutes after 2nd detection;
4th detection will be happened in 10 minutes after 3rd detection;
5th hereafter detection will be happened every 30 minutes;

3. Unit Mounting

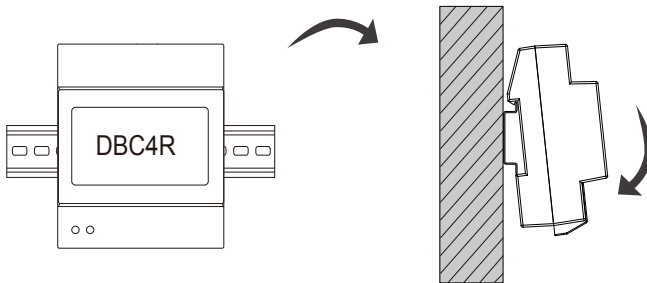

DIN Rail Mounting

4. System Wiring with DBC4R

1. Basic IN-OUT expansion wiring(distributor mode)

Cable Usage	A	B
Twisted cable 2x0.75 mm ²	75	65
Twisted cable 2x1.00 mm ²	80	70

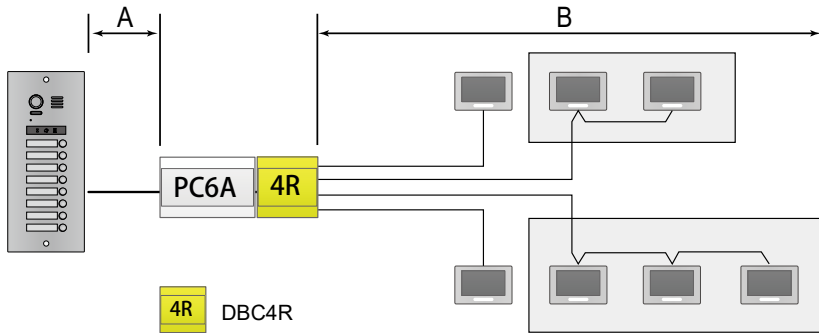

Wiring diagram:

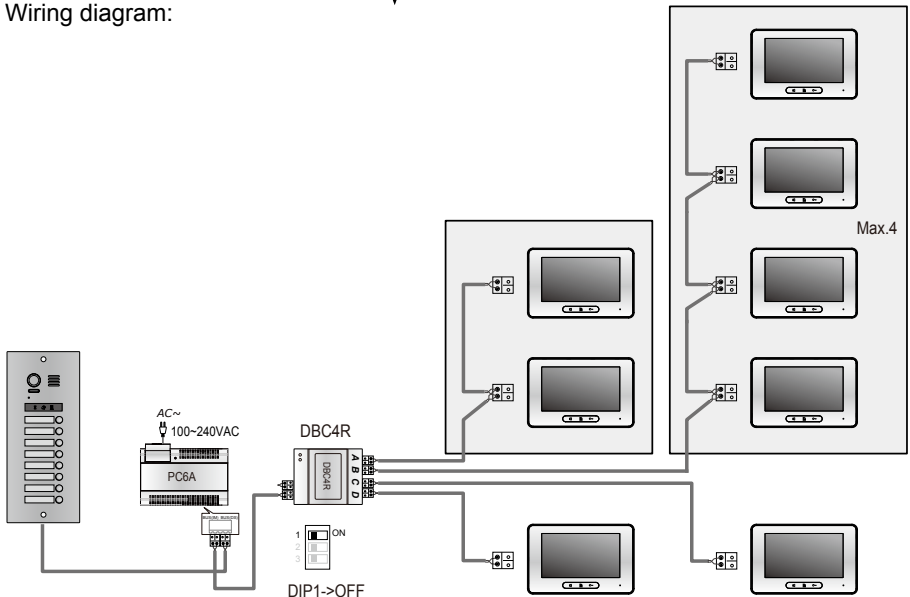

* Max.8 monitors can be connected for every DBC4R.

2. Multi risers wiring(riser mode)

Cable Usage	A	B	C
Twisted cable 2x0.75 mm ²	75	65	30
Twisted cable 2x1.00 mm ²	80	70	35

Type 1

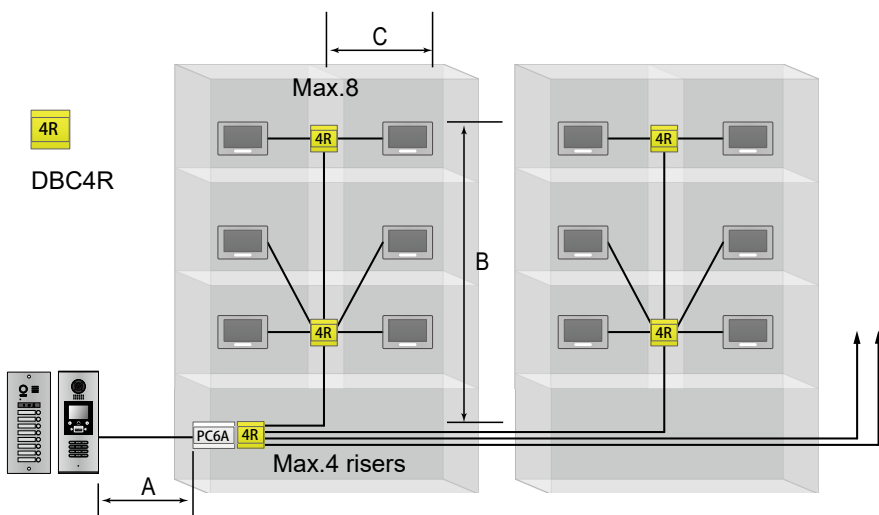

Wiring diagram:

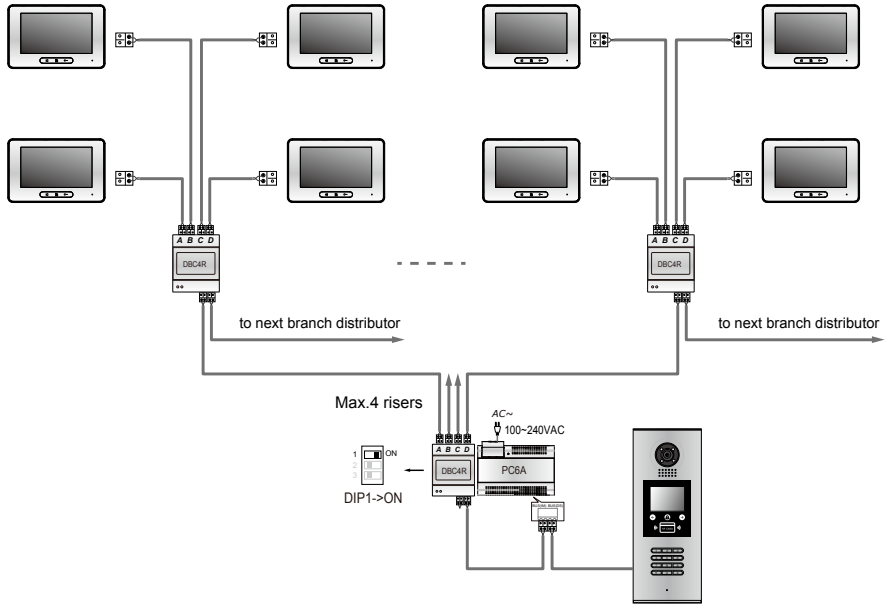

Wiring diagram:

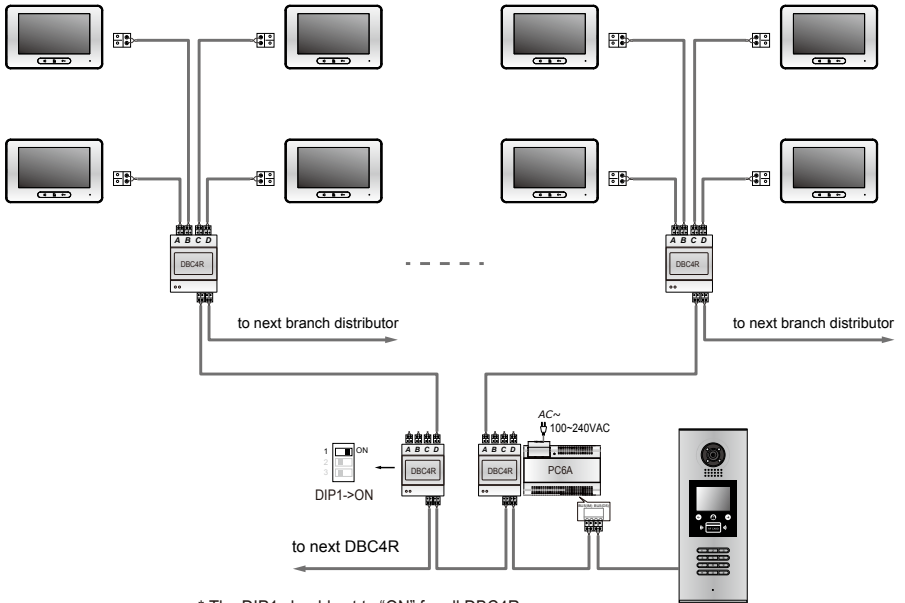

* The DIP1 should set to "ON" for all DBC4R.

3. Multi monitors wiring(distributor mode)

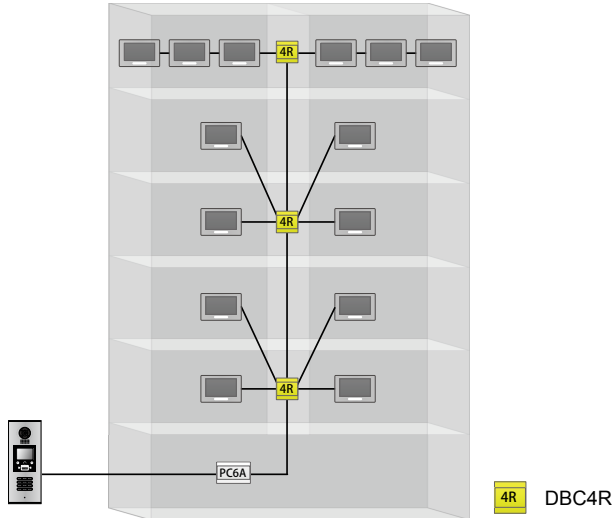

Wiring diagram:

* The impedance switch should set to "ON" for the last DBC4R at the end of the bus.

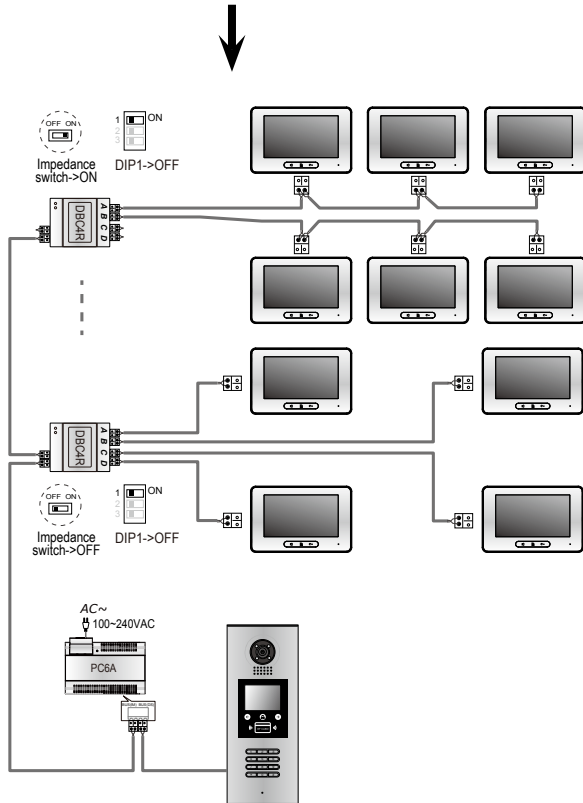

5. Specification

Power Supply :	DC20~30V
Working Temperature:	-10°C~+40°C
Wiring:	2 wires (non-polarity)
Dimension:	89(H)×71(W)×45(D)mm
Standby Current:	4~5mA

The design and specifications can be changed without notice to the user. Right to interpret and copyright of this manual are preserved.